DediProg

4F., No.7, Ln. 143, Xinming Rd., Neihu Dist., Taipei City 114, Taiwan

SF600

Serial Flash Programming solutions

The Innovative solution to update the Serial Flash on board and Offline

- *High performances*
- *USB High speed support*
- *In Circuit Programming (program on board SPI Flash)*
- *Off line Programming (program SPI flash in the socket)*
- *Stand Alone mode (optional): Update the Serial flash without computer*
- *Isolation Free: program on board SPI Flash without isolation circuit
DediProg unique IP (patent protected)*
- *Support single, Dual and quad IO*
- *Three software optimized interfaces:*
 - *Engineering Interface for expert*
 - *Command Line for automatic control*
 - *Production interface for operator*
- *Multi-Programmable support through USB*
- *Friendly and powerful tool with free life time update via Website*
- *Portable programmer*
- *Advanced I/O control*

Table of content:

I.	Products comparison	3
II.	SF600 description	3
A.	Interface description.....	4
B.	ICP Header description	5
C.	Application Header	6
1.	Backward compatibility with SF100	6
2.	Application Universal Header.....	7
3.	Pin Header pitch.....	7
D.	“Isolation Free” Application Header.....	7
III.	Programming methods	8
A.	In Circuit Programming	8
1.	SPI bus in High Impedance.....	9
2.	SPI bus isolation circuit	9
3.	Isolation free method	9
4.	Backup Boot Flash method.....	10
B.	Off line Programming	11
IV.	SF600 software	12
A.	USB mode	12
1.	Engineering User Interface	12
2.	Command line interface	12
3.	Production User interface	13
B.	Standalone mode	14
1.	Project Preparation.....	14
2.	Mode switch.....	15
3.	Standalone programming	15
V.	Specification	15
A.	USB Connector	15
B.	DC and IO characteristics	15
1.	Socket DC Characteristics	15
2.	ICP DC and AC characteristics.....	15
3.	ICP timing.....	18
4.	Host PC requirements	19
VI.	Programming Performance	20
A.	USB Mode.....	20
A.	Revision history	20

Important notice:

This document is provided as a guide line and must not be disclosed without consent of DediProg. However, no responsibility is assumed for errors that might appear.

DediProg reserves the right to make any changes to the product and/or the specification at any time without notice. No part of this document may be copied or reproduced in any form or by any means without prior written consent of DediProg.

I. Products comparison

The Universal Programmers available on the market are not optimised for the Serial Flash and offer low performances for high price. DediProg team has therefore developed the optimum solutions to cover all our customers' needs.

Table1: Comparison table

Features	SF100	SF200	SF300	SF600 (new)
Support all Serial Flash	V	V	V	V
USB Full speed	V	V	V	
USB High speed				V
In Circuit Programming	V		V	V
Off line Programming		V	V	V
Stand Alone mode			V	V
Multi-Programmiers USB	V	V	V	V
Engineering GUI	V	V	V	V
Command Line	V	V	V	V
Production GUI	V	V	V	V
Backup Boot Flash	V	V	V	V
Single IO	V	V	V	V
Dual IO				V
Quad IO				V
Isolation Free				V

II. SF600 description

SF600 has been designed to offer the best possible performances to program the SPI Flash in different conditions.

A. Interface description

Fig 1: SF600 Programmer

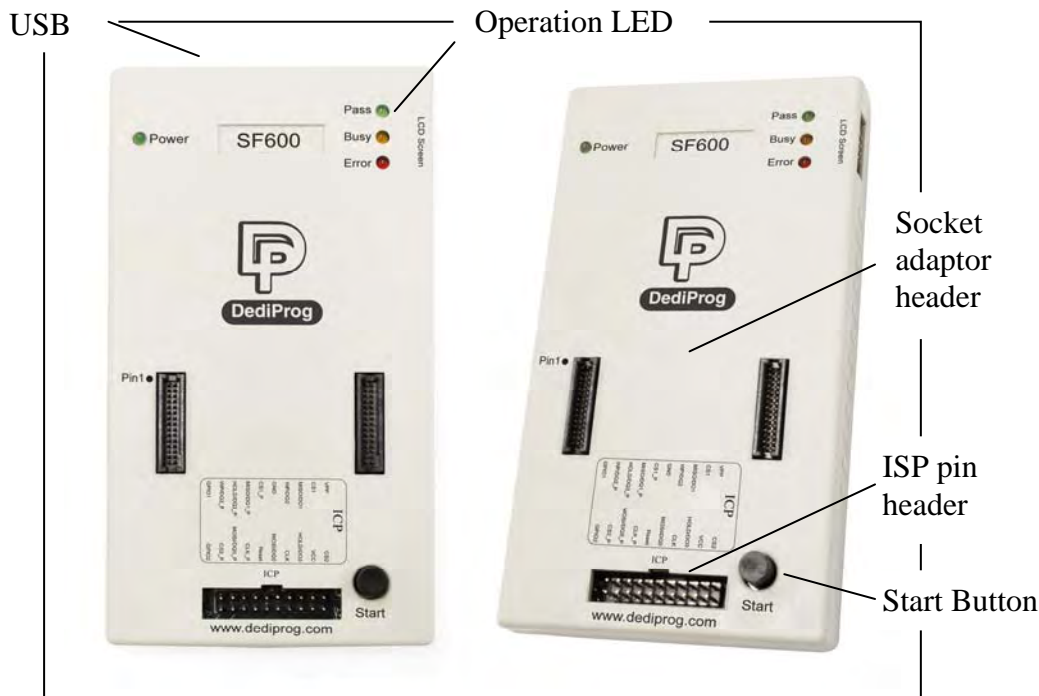

The SF600 hardware description:

- **USB male Connector:** To connect the programmer to the computer. A USB cable extension is provided for flexibility and convenience.
- **Socket Adaptors connector:** to plug the DediProg socket adaptors and program the Serial flash off line. DediProg is providing different socket adaptors to fit the market SPI Flash packages. Review the socket adaptor available on DediProg

fig 2: Socket adaptors



- **LED:** to indicate the status of the operation in progress

- **Start button:** to start operations from the programmer either in USB mode or Stand Alone mode. By pressing the start button, the SF600 starts to execute the operation procedures defined in the software Batch configuration when working in USB mode or in the project pre-loaded to the SF600 when working in Stand Alone mode

B. ICP Header description

The **In Circuit Programming Header and cable** are used to program the on board Serial Flash. The flat cable is flexible and convenient to manipulate. It must be kept as short as possible to not impact the signal quality. Even if SF600 strong buffers can drive high capacitance, the communication failure can occur due to weaker driving capability of the on board Serial Flash. In case of communication problems, try to reduce the bus frequency from the software interface.

For customization of the ICP-cable (number of signals, pin out assignment or connector size), please contact Dediprog. DediProg is providing additional accessories to fit your target board like:

- ICP split cable: you can connect each signal individually according to your own pins assignment
- SO Test Clip: you can connect the SF600 directly on the Serial flash SO package (SO8N, SO8W, SO16W)

Table 2: Sf600 Pin Header description:

1	Vpp	CS2	2
3	CS1	Vcc	4
5	MISO/DQ1	Hold/DQ3	6
7	Wp/DQ2	CKL	8
9	GND	MOSI/DQ0	10
11	CS1_P	Reset	12
13	MISO/DQ1 P	CKL P	14
15	Hold/DQ3 P	MOSI/DQ0 P	16
17	Wp/DQ2_P	CS2_P	18
19	GPIO1	GPIO2	20

Table 3: Description of the signals:

Pin Number	Name of the signals	Description
1	Vpp	High voltage applied on the SPI Flash to speed up the programming and erasing operations
2, 3	CS1, CS2	Chip select of the two Serial Flash. Serial Flash 1 or 2 can be selected from the software
4	Vcc	Vcc is used to supply the application SPI Flash. The Vcc level can be adjusted from the software. A diode protects the SF600 Vcc from the application Vcc.
5	MISO/DQ1	Data out from the application memory (master in slave out) when memory work in single IO mode. Bi-directional when memory works in Dual or Quad IO mode.
6	Hold/DQ3	Driven High when Hold function is active. Bi-directional when memory works in Quad IO mode.
7	Wp/DQ2	Driven High when Wp function is active. Bi-directional when memory works in Quad IO mode.
8	CLK	SPI clock signal
9	GND	GND is the common ground shared between application and programmer
10	MOSI/DQ0	Data in of the application SPI Flash (master out slave in) when memory work in single IO mode. Bi-directional when memory works in Dual or Quad IO mode.
12	Reset	Open drain output driven low prior any SF600 operation. Reset can be used to turn on the application isolation circuit or reset the target system in order to drive the Serial bus in High Impedance.
11, 13, 14, 15, 16, 17, 18	XXX_P	XXX_P are used to protect the chipset from current leakage during “isolation Free” method. Refers to DediProg “isolation Free” reference design and application note for more details.
19, 20	General purpose I/O	General I/O can be used for customization.

C. Application Header

1. Backward compatibility with SF100

The SF600 pin Header assignment has been changed versus the SF100 in order to support the new Serial Flash features like Quad IO and to be compatible with others DediProg development tools like EM100 SPI Flash emulator and Backup Boot Flash tools. If your application has been designed for the SF100, DediProg is providing with the SF600 an adaptor to be backward compatible.

2. Application Universal Header

For new application design, DediProg strongly recommend to implement the universal Header so you can benefit of all the development tools available and future features of the Serial Flash and controllers.

- One or two Serial Flash programming
- Single, dual and Quad IO programming
- Controller Reset mode

Table 4: Universal Pin Header for application design

1	Vpp	CS2	2
3	CS1	Vcc	4
5	MISO/DQ1	Hold/DQ3	6
7	Wp/DQ2	CKL	8
9	GND	MOSI/DQ0	10
11	NC	Reset	12

NC: Not connected

It is recommended to keep the Header 2*6 even if some signals are unused (Vpp, CS2, Hold, Wp, reset). The header will stay compatible with the female connector supplied by default with the SF600.

Pin 11 can be used as insertion mistake proof pin. To support this protection of wrong insertion, the pin 11 has to be cut in the application and the corresponding hole of the cable connector must be filled accordingly.

3. Pin Header pitch

The default cable and female connector provided with SF600 is a 2.54mm pitch. For space saving reason, you may decide to implement a 1.27mm pitch header on your application board. DediProg proposes an adaptor board to convert from 2.54mm to 1.27mm.

D. “Isolation Free” Application Header

“Isolation free” method offers the highest flexibility of code update as described in the following section. The on board Serial flash can be updated even if the application has not been designed for such purpose or if the isolation circuit has been removed in production for cost reason..

With “Universal Header”

“Isolation free” method can be used with the “Universal Header” but will generate some leakage current through the application controller.

With controller Protection:

DediProg has developed a method to protect the application controller from leakage current. The xxx_P signals have to be connected to the corresponding signals on the controller side.

Table 5: “Isolation free” application header

1	Vpp	CS2	2
3	CS1	Vcc	4
5	MISO/DQ1	Hold/DQ3	6
7	Wp/DQ2	CKL	8
9	GND	MOSI/DQ0	10
11	CS1 P	Reset	12
13	MISO/DQ1 P	CKL P	14
15	Hold/DQ3_P	MOSI/DQ0_P	16
17	Wp/DQ2 P	CS2 P	18
19	NC	NC	20

NC: Not connected

For space saving reason, you may decide to implement a 1.27mm pitch connector on your application board. DediProg proposes an adaptor board to convert from 2.54mm to 1.27mm.

DediProg is also proposing a “probes connector” solution so your application does not need to solder the header but only layout the footprint. Please contact DediProg for more information.

For “isolation free” design or more information, ask for DediProg reference schematic and In Circuit Programming application note.

III. Programming methods

A. In Circuit Programming

The **SF600** programmer has been designed to meet the strong and growing demand of serial flash users to program and update the memories soldered on board during development, production, field manipulation or repairing with high performance and low cost.

Important:

Socket adaptor and In Circuit Programming cannot be used in the same time. To use the In Circuit programming, the socket adaptor has to be removed.

SF600 can support dual and quad IO programming offering the shortest programming time even if the application board total capacitance do not permit high frequency.

Before trying to update the Serial Flash soldered on Board, make sure that the SPI controller and the application are compatible with the In Circuit Programming method to avoid any conflict with the programmer.

Fig 3: SF600 connected to the application header



1. SPI bus in High Impedance

The SF600 reset signal can be used to reset the target board and switch the application controller in reset mode. User must check if the SPI bus is released in high impedance during this mode to prevent any conflict between the programmer and the application controller. In this mode, the on board flash is supplied by the application.

2. SPI bus isolation circuit

If the application controller does not release the SPI bus in high impedance during reset then an isolation circuit (MOSFET, switch, multiplexer..) must be designed in order to isolate the programmer and serial flash from the application controller during the update.

DediProg has published an Application Note and reference schematic to help designers to implement the In Circuit Programming method and will be pleased to answer any of your questions on this subject.

3. Isolation free method

SF600 is the only programmer in the market able to support the isolation free method. Isolation free method is the ideal solution if the application controller does not release the SPI bus in high impedance during reset and if the isolation circuit has not been implemented due to cost reason or design history.

Actually, isolation circuit is increasing the cost of the application board and it is often only implemented for development purpose and removed from the board for mass production. Isolation free method offers the advantage to keep the on board updates flexibility before, during and after the production.

Code programming or Update flexibility:

- **For code trials during Research and Development (R&D)**
- **For Production programming**
- **For application code update or customization in warehouse**
- **For repairing or update in the field**

DediProg has published an Application Note and reference schematic to help designers to implement the “isolation free” method and will be pleased to answer to any of your questions on this subject.

4. Backup Boot Flash method

SF600 can also be used together with DediProg backup boot flash modules so that it forces the application to boot from the backup flash located in the backup boot flash module instead of the soldered SPI flash on the application which it is disabled. The backup serial flash can then be accessed at any time by the SF600 without any possible conflict with the application controller. In this case, SF600 cannot update directly the on board Serial Flash to avoid conflict with the controller.

Applications:

- **Development purpose** as the system can boot from the backup Flash for the code trials. Engineer can update safely the backup Flash with new code and without any conflict risk with the application controller.
- **Repair purpose** as the system can still boot from a backup memory even if the on board Serial flash is corrupted. The technician can use the application flash update tools after the boot to update the on board Serial flash.

Remark: Pin header adapter need to be used

Fig 4: Backup Boot Flash (BBF) connected to SF600

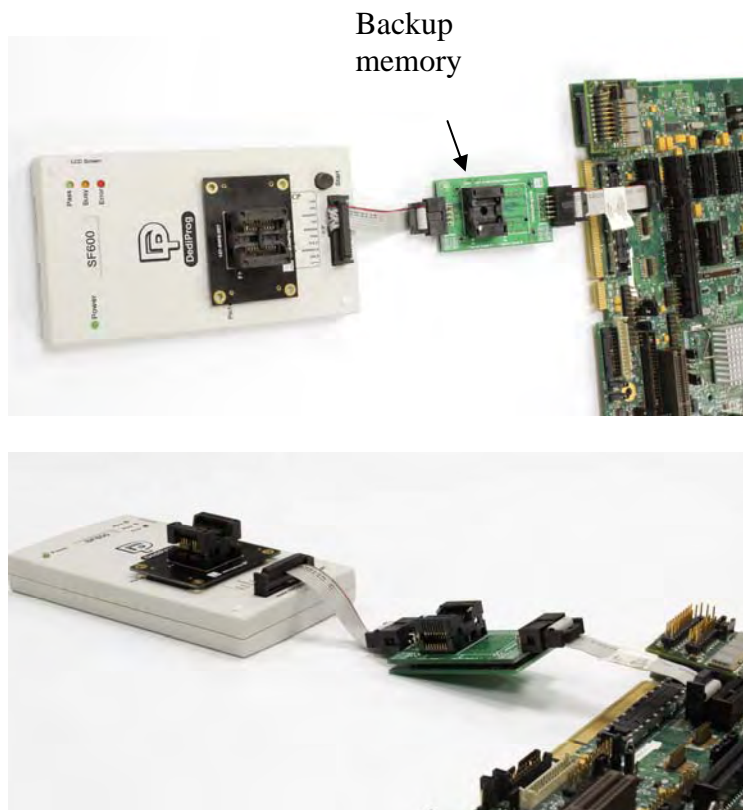

B. Off line Programming

The SF600 has been designed to support the DediProg socket adaptors and offer the off line programming flexibility. Different sockets adaptor are provided to fit the different Serial Flash packages proposed in the market.

For development:

Off line programming can be used during development when an engineering socket is soldered in the target application board so that Serial Flash can be manually removed and programmed in the SF600 socket. DediProg supplies engineering sockets which are footprint compatible with the SPI Flash.

For Production:

Off line programming can be used to program the Serial Flash before soldering. DediProg software supports multi-programmers through USB to program few serial Flash in parallel and SF600 also supports Stand Alone mode. For high volume production, DediProg recommends to use the Race100 Serial Flash Gang programmer.

Fig 5: SF600 with Socket adaptor



Important:

Socket adaptor and In Circuit Programming cannot be used in the same time. To use the off line programming, the in Circuit Programming cable has to be unconnected.

IV. SF600 software

A. USB mode

In USB mode, user can control the programmer operations via a friendly interface. He can load a file, blank check, program and verify the target Serial Flash. Batch button provides an easy way to perform more than one operations in one click. User can also edit the buffer, files and SPI Flash content and compare.

DediProg provides three different users interface to fit better our customers' needs. For more information on the SF600 software, please refers to the user manual.

1. Engineering User Interface

The engineering user interface has been designed to offer the expert features for engineers during development.

Fig 6: Engineering GUI

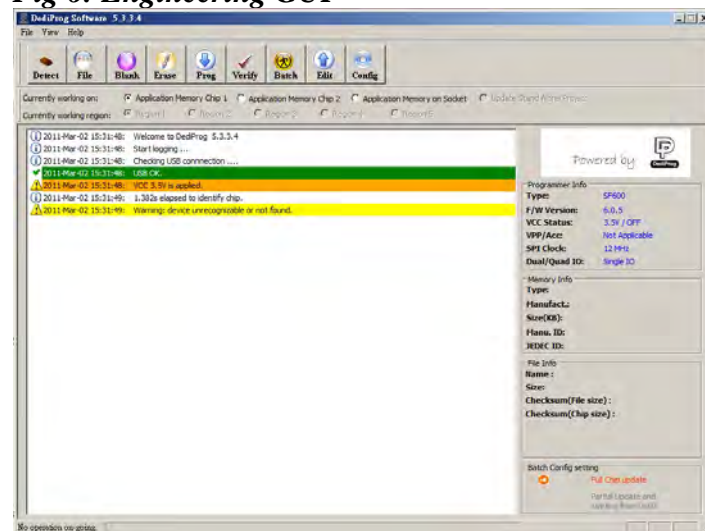

2. Command line interface

The command line interface has been designed to offer a faster user control of the programmer or an automatic control of the programmer from another software.

Faster control:

User can quickly perform some repetitive operations just by typing the command on our Window DOS interface.

Automatic control:

The Command line can also be called by another software to take the control over the programmer.

Benefits:

- SF600 can be controlled by the **compiler** in order to automatically program the Serial Flash with the new code for trials

- SF600 can be integrated in your production line and be controlled by the **In Circuit Tester** to program the on board serial flash after the testing has been successfully performed.

Fig 7: Window DOS interface

```

C:\>
C:\>set path=%path%;"c:\program files\dediprogram\inc\dedipro programmer"
C:\>dpcmd -uc:\M_55.bin
DpCmd 1.1.0, Engine Version: 2.0.33.
Last Built on Nov 22 2006
Copyright (C) 2006 Dediprogram. All rights reserved.
M25PE80 detected.

Auto sequences Operating, please wait ...
Time elapsed: 26.688s
Automatic program OK
Checksum(file): 0000
C:\>dpcmd -pc:\M_55.bin -a0x010
DpCmd 1.1.0, Engine Version: 2.0.33.
Last Built on Nov 22 2006
Copyright (C) 2006 Dediprogram. All rights reserved.
M25PE80 detected.

Reading, please wait ...
Time elapsed: 4.596s
Read OK
Erasing, please wait ...
Time elapsed: 15.422s
Erase OK
Programming, please wait ...
Time elapsed: 8.573s
Program OK
Checksum(file): 00aa
C:\>

```

3. Production User interface

The production user interface has been designed to offer the optimum interface to control volume programming:

- Simple interface to fit to the operator needs
- Project loading to reduce the human errors
- Monitor multiple programmers operation in one window
- Control your on going project performances (counters, failure rate..)

Fig 8: Production GUI

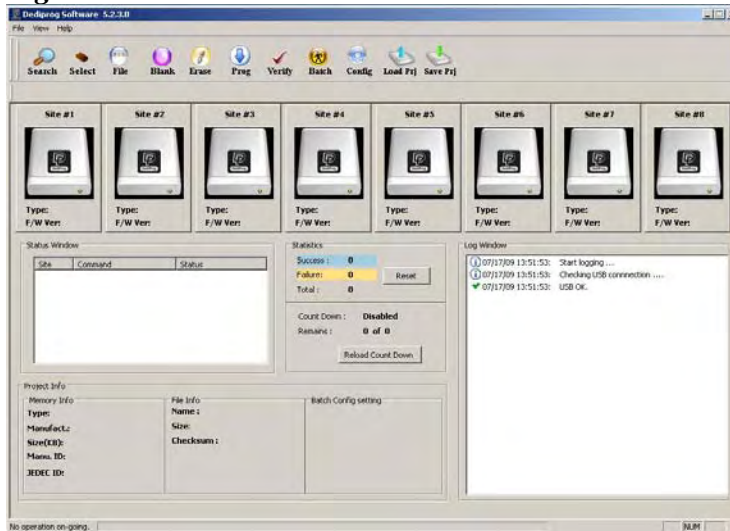

B. Standalone mode

The SF600 has been designed to work in Stand Alone mode. The stand alone mode is optimized for production as each programmer does not require to be connected to the computer.

To work in Stand Alone mode, SF600 needs to be connected to DediProg “control module” with display and Keypad. SF600 will also use the SD card to run the project.

Standalone mode procedures:

1. Project definition from the engineering interface
2. Save Project on the SD card
3. Run project from SF600 by using the DediProg “control module”

1. Project Preparation

In order to perform stand alone programming, the contents and the programming operation procedures have to be pre-downloaded to the SF600 SD card through the USB with the software provided by Dediprogram.

Prepare a standalone programming project

1. Connect the SF600 to a computer with DediProg software installed and make sure the programmer is switched to USB mode by removing the “control module”
2. Load the file to be programmed
3. click on “Configuration” icon to select the target chip type and the standalone operation procedures
4. Project has to be downloaded in the SF600 SD card from the user Interface

Fig 9: SF600 Stand Alone software interface

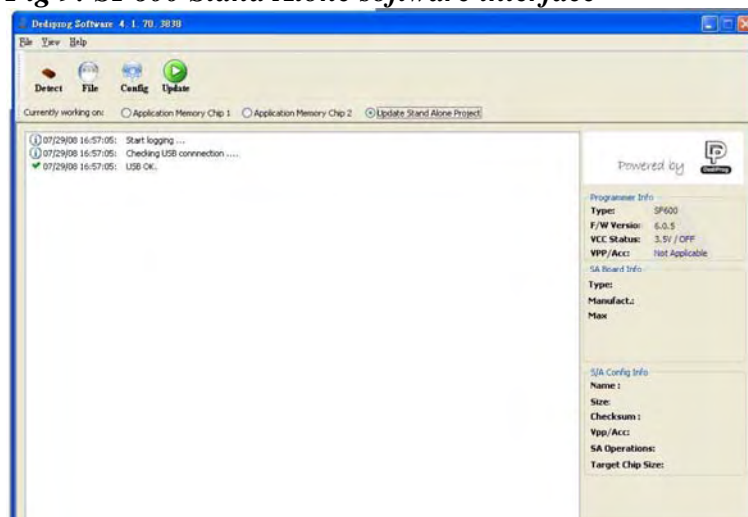

2. Mode switch

SF600 switch automatically from USB mode to Stand Alone mode when the DediProg “control module” is connected.

- **USB mode:** to control the programming via the computer tool
- **Stand Alone mode:** to work independently from computer

3. Standalone programming

When the project is available in the SF600 SD card and the “control module” connected, the user can select and run the project from the display and keypad:

1. Select the project from the SD card
2. Start the project

V. Specification

A. USB Connector

The USB connector type A is available to communicate with the computer tool or to supply the programmer in Stand Alone mode. When in Stand Alone mode, the SF600 has to be supplied through the USB connector or the 5V power jack. This could be achieved by:

- Connecting the SF600 to a computer for the USB power
- Connecting the SF600 to a standard USB Hub (500mA min)
- Connecting the SF600 to the 5V/1A power adaptor through the power jack

USB Power supply specification:

- **Vdd = 5V ± 5%**
- **Idd min = 500mA**

B. DC and IO characteristics

1. Socket DC Characteristics

User can adjust the power supply of the target Serial Flash from the software interface. The Vcc can be set from 1.2V to 3.6V.

The SPI signals levels are generated according to the Vcc selected.

2. ICP DC and AC characteristics

The ICP connector is a 10x2 pin header straight type with 2.54mm pitch. It is used to control the application SPI Flash, and if necessary supply the SPI Flash, provide the high voltage to the SPI Flash, or reset the application chipset, etc.

Table 6: Sf600 Pin Header description:

1	Vpp	CS2	2
3	CS1	Vcc	4
5	MISO/DQ1	Hold/DQ3	6
7	Wp/DQ2	CKL	8
9	GND	MOSI/DQ0	10
11	CS1_P	Reset	12
13	MISO/DQ1 P	CKL P	14
15	Hold/DQ3 P	MOSI/DQ0 P	16
17	Wp/DQ2_P	CS2_P	18
19	GPIO1	GPIO2	20

a) Application SPI Flash supply: Vcc

Specification for the ICP Vcc pin:

- Vcc is set at 3.3V by default and can be adjusted down to 1.2V from the software interface
- Icc max supplied = 100mA

The application SPI Flash can be supplied by two different sources:

- 1) by the programmer via ICP Vcc pin at 3.3V
- 2) by the application according to the SPI Flash specification

The SF600 has been designed with a Serial diode on the Vcc to protect against any conflict with the application Vcc.

b) SPI signals management: CS1, CS2, CLK, MISO, MOSI, DQ0-4, IO, reset

The SPI signals are used to communicate with the application SPI Flash with a high frequency (up to 25MHZ). The frequency can be also adjusted from the software interface. The signals are CMOS compatible and are switched in High Impedance when not used. The SPI signals are turned in Low impedance after reset has been driven low.

Table 7: DC specification for SPI signals and IO

Symbol	Parameter	Test condition		Value	Unit
		Vcc(V)	Io(mA)		
Vih	High Level Input Voltage	2.7V to 3.6V		2V	V min
		2.3V to 2.7V		1.7V	V min
		1.65V to 1.95V		0.65XVcc	V min
Vil	Low Level Input Voltage	2.7V to 3.6V		0.8V	V max
		2.3V to 2.7V		0.7V	
		1.65V to 1.95V		0.35XVcc	
Ioh	High Level Output current	3V	-24mA		mA
		2.7V	-12mA		mA
		2.3V	-12mA		mA

		1.65V	-4mA		mA
Iol	Low Level Output current	3V	24mA		mA
		2.7V	12mA		mA
		2.3V	12mA		mA
		1.65V	4mA		mA
Cap	Capacitance			10nF	nF typ

This specification is relative to individual capability of one signal.

ESD high performance protection compliant with IEC61000-4-2 level 4:
15kV (air discharge)
8kV (contact discharge)

Remark: the total capacitance added on the application SPI bus will also depend on the ICP cable length. The ICP cable length must be reduced at the minimum. The SPI flash output buffer capability (MISO) is limited compared to the programmer performances. So even if the programmer is able to drive high capacitance, the Serial Flash soldered on the application will probably not (information read from SPI Flash will be wrong).

d) Smart management of the SPI Flash Vcc and SPI signals

In order to minimize the impact of the ICP method on the chipset and application board, the programmer supplies the application Serial Flash with Vcc and SPI signals only during the programmer and Serial Flash operations.

Advantages:

- The programmer is plugged on the application board with Vcc OFF and SPI signals in High Impedance to avoid inrush current.
- All the ICP pins are protected with ESD high performance protections to discharge the Electronics charge before the connection and protect the application.
- The Serial Flash Vcc and SPI signals are provided only when the user send the command and are switched OFF automatically when the operation is completed. Therefore, the programmer is transparent for the application and can be kept connected during application trials.

e) High voltage supply: Vpp/Acc

Specification for the Vpp pin

Vpp = 5V to 12V

Ipp max = 70mA

The Vpp high voltage can be supplied by the programmer and used to speed up programming and erasing of the application Serial Flash if this feature is supported by the Serial Flash supplier.

The Vpp supply will be applied automatically by the programmer on the Vpp pin only during erase, write, or programming operations and only if the Vpp option has been enabled on the software. The programmer will also control the Vpp voltage level according to the Serial Flash connected and its specification.

f) I/O management: IO1, IO2, Reset

Two general IO are available on the ICP connector and one Reset for custom needs. The IOs and reset are in High Impedance (HZ) state if there is no software operation ongoing.

Reset: The reset pin is an open drain output which can be used to reset the target system or turn off the isolation circuit.

Fig 10: Circuit diagram:

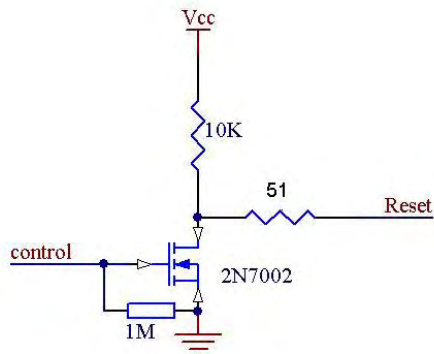

IO: The IO signals are in input mode by default. Behavior to be customized. For the DC characteristics of IO1 and IO2 please refer to the DC table.

ESD high performance protection compliant with IEC61000-4-2 level 4:
15kV (air discharge)
8kV(contact discharge)

3. ICP timing

The IO and reset have been designed to set the application in programming mode before applying the SPI signal. They can be used to reset the target application, to turn OFF MOSFET and isolate the SPI bus when programmer is working.

1) If No programmer operation is on going

All our SF600 outputs are equivalent to high impedance.

2) When an operation is requested on the user interface

- IO1, IO2 are kept in Input by default (High Impedance)
- Reset signals is driven Low.

4) 3ms after Reset is switched to Low Impedance, the SPI outputs are switched in low impedance too.

- CS1 and CS2 are driven high
- Clock and MOSI are driven low
- DQ0-3 are driven low if Quad IO outputs is enable
- Hold, Wp are driven High if single IO mode is used

5) The programmer is then ready for the communication with the Serial Flash.

So designer can use the Reset signal to reset or switch the application Serial bus in High impedance. Application controller or circuitry will have a delay of 3ms between Reset is driven low and Programmer SPI outputs are switched from High Impedance to Low Impedance. SPI communication starts 6ms after reset has been driven low.

6) When operation on the memory is finished, the SF600 are switched in High impedance so the application board can boot with SF600 connected without conflict.

Fig 11: IO and SPI timing

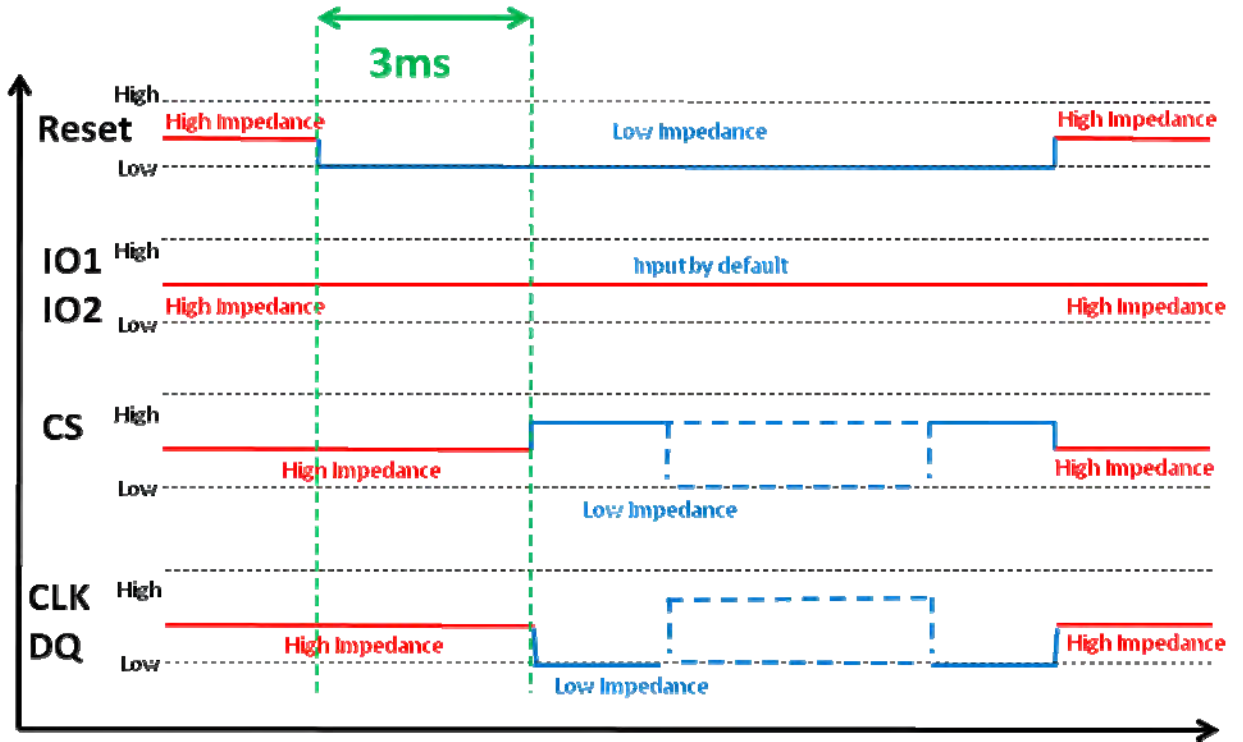

4. Host PC requirements

The SF600 interfaces with IBM compatible PC's through the USB 2.0/1.1 port. This gives full compatibility with the latest PC's, notebooks and portables.

System Requirements:

- PC with Windows XP / Vista / Win7
- Hard disk with at least 64 MB free space.

System Interface:

- PC connexionUSB 2.0/1.1 port

VI. Programming Performance

A.USB Mode

Table 8: Programming and verify in USB mode

SPI Flash Densities	8Mb	16Mb	32Mb	64Mb	128Mb
USB	8s	14s	37s	70s	108s

A.Revision history

Date	Version	Changes
01/03/11	March 11	First release

DediProg Technology Co. Ltd

4F., No.7, Ln. 143, Xinming Rd., Neihu Dist., Taipei City 114,
Taiwan

Email for technical support: support@dediprog.com

Email for Sale information: sales@dediprog.com

www.DediProg.com

Information furnished is believed to be accurate and reliable. However, DediProg assumes no responsibility for the consequences of use of such information nor for any infringement of patents or other rights of third parties which may result from its use. Specifications mentioned in this publication are subject to change without notice. This publication supersedes and replaces all information previously supplied.

All rights reserved
Printed in Taiwan.