

DediProg

In Circuit Programming Solution for Serial flash



Dec 08

In Circuit Programming method (ICP) Introduction

Benefit of the highest update flexibility for development, debugging, production and repairing by using our In Circuit Programming method allowing to reduce your time to market.

Features: update your SPI Flash soldered on your application board by using our dedicated programmers: SF100 and SF300. When connected to the application board, the programmer can control the SPI bus to read or update the Serial Flash content.



In Circuit Programming method (ICP) benefits

Benefits:

- The highest performances (SPI Flash dedicated Programmer)
 - 8Mb = 10sec for update
 - 16Mb = 20sec for update
- The highest code update flexibility for code development, debugging warehouse update or repairing (any where at any time)
- The easiest update method for final users
- Reliable (no contact problem due to socket or soldering)
- Ensure the best SPI signals quality versus the socket solution (less bus capacitance)
- Time saving (no need to manipulate the memory or unsold for update) for the best time to market



Benefits of the highest update flexibility

Update flexibility is a must:

- For Reference Board: convenient for your customers trials
- For software development: ensure new code trials in the shortest time
- For Code debugging: easy access and editing of the memory content at any time
- For Production: Program the code after soldering or at the last time for customization before shipment
- For update: in warehouse before shipping in case of new code version
- For repairing: easy field repairing in case of code bug or corruption
- ..

ICP versus IAP and ISP

IAP = In Application Programming (use the application software to update the Flash)

ISP = In System Programming (Use an external tool to update the Flash through the application controller)

ICP = In circuit Programming (Use external tool to update directly the Flash on board)

IAP or ISP

ICP is optimized and faster than IAP and ISP

Application communication (IAP)

Or External tool (ISP)

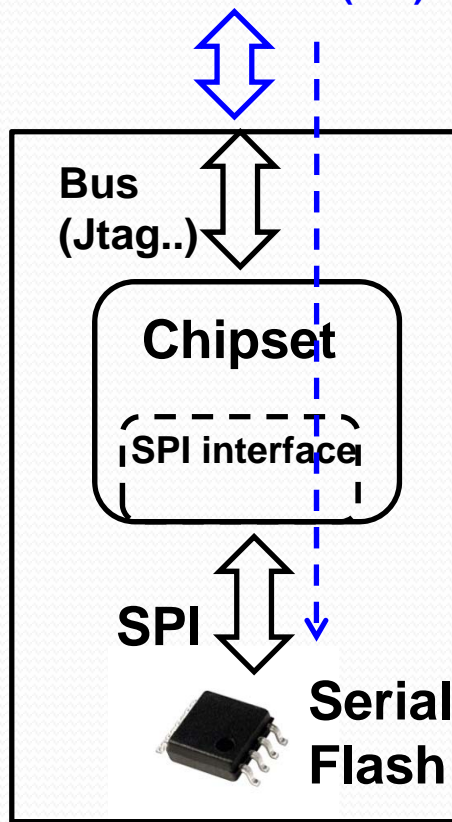

IAP and ISP are often limited by:

- External low bus interface
 - Transfer through chipset
 - Chipset SPI interface
- (For Die cost reduction, the chipset SPI buffer is often reduced to few bytes 8, 16 and optimized for fast read but not for fast Serial Flash Programming)

ICP

SF100
Or SF300

In Circuit Programming is optimized for Serial Flash:

- Optimum frequency
- Optimum SPI buffer (256Bytes)
- No limitation due to cost reduction

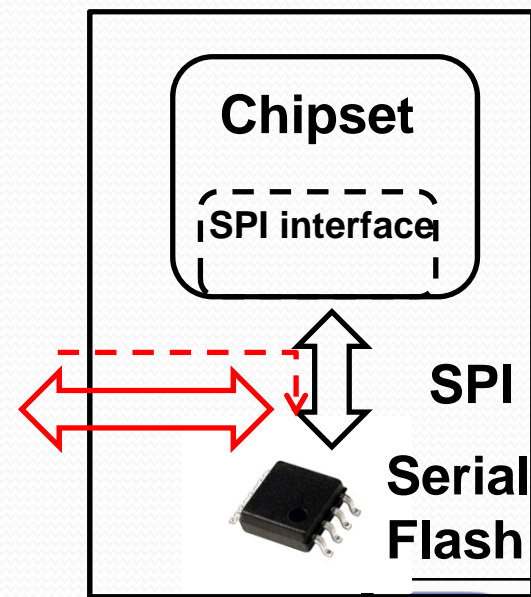

Application



DediProg

The SF100 and SF300 ICP programmer

The In Circuit Programmers take advantage of the Low lines count of the SPI bus (4 lines only) to take the control of the memory.

These programmers have been designed to fit the different applications needs and optimized for the Serial flash offering powerful features, high performance for the lowest cost.

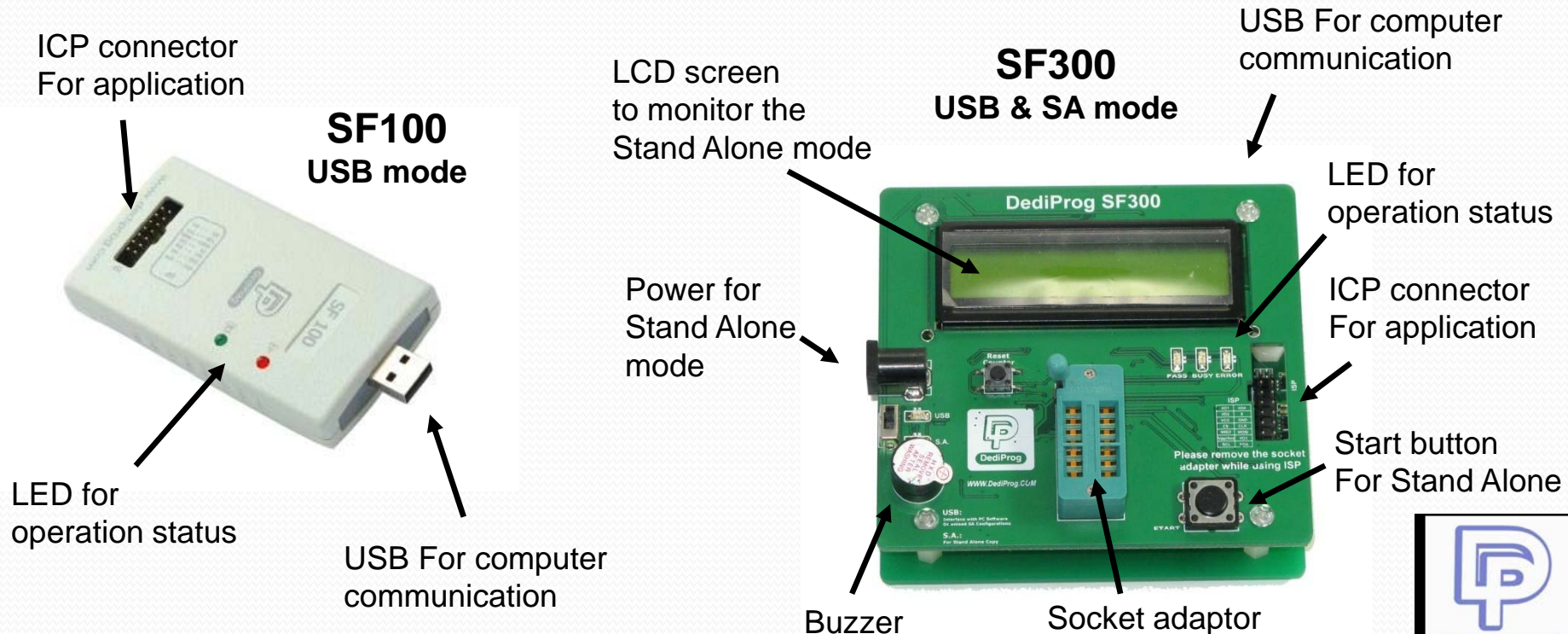

ICP connector description

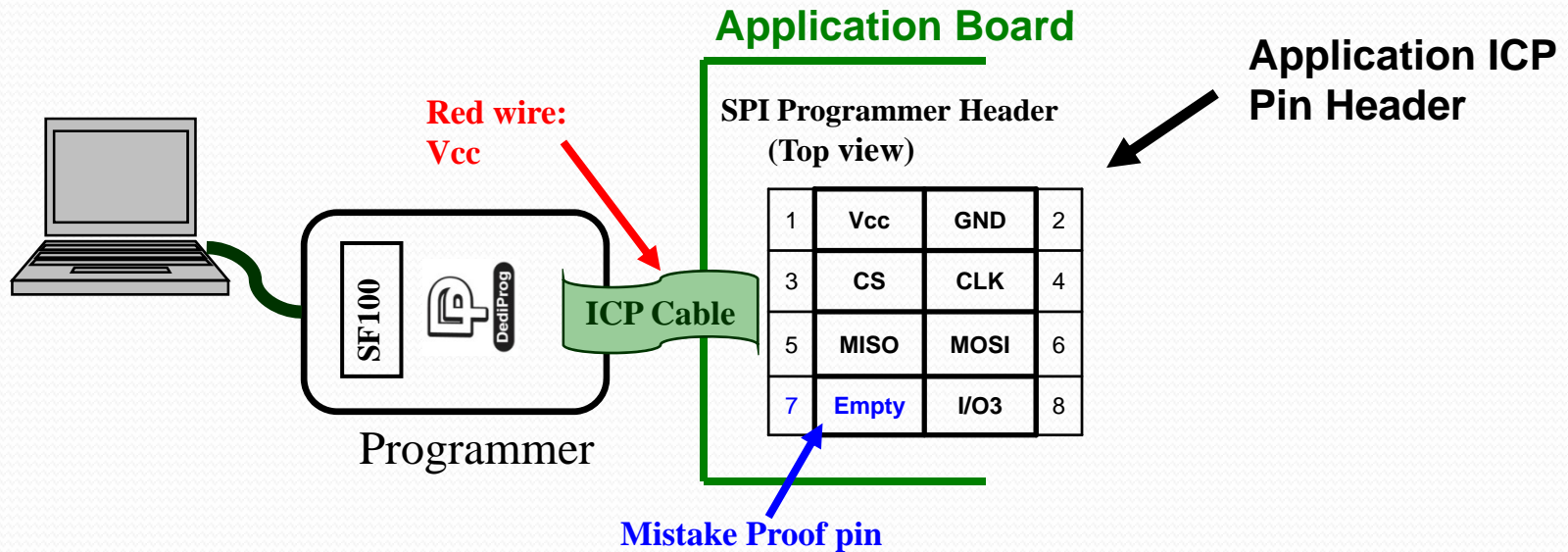

Pin	Name of signal	Description
1, 2	Vcc, Gnd	Vcc supplied from the programmer to the Serial Flash
3, 4, 5, 6	CS1, CLK, MISO, MOSI	SPI signals
8	IO3	Used to reset the Chipset or switch off the Mosfet
7	Mistake proof pin	Prevent from wrong connection

Solutions to implement the ICP method

Case 2: Update the Serial Flash with Application OFF and Mosfet

- Mosfet to not supply the application with the programmer Vcc
- Application ON → MOSFET ON
 - Application OFF → MOSFET OFF

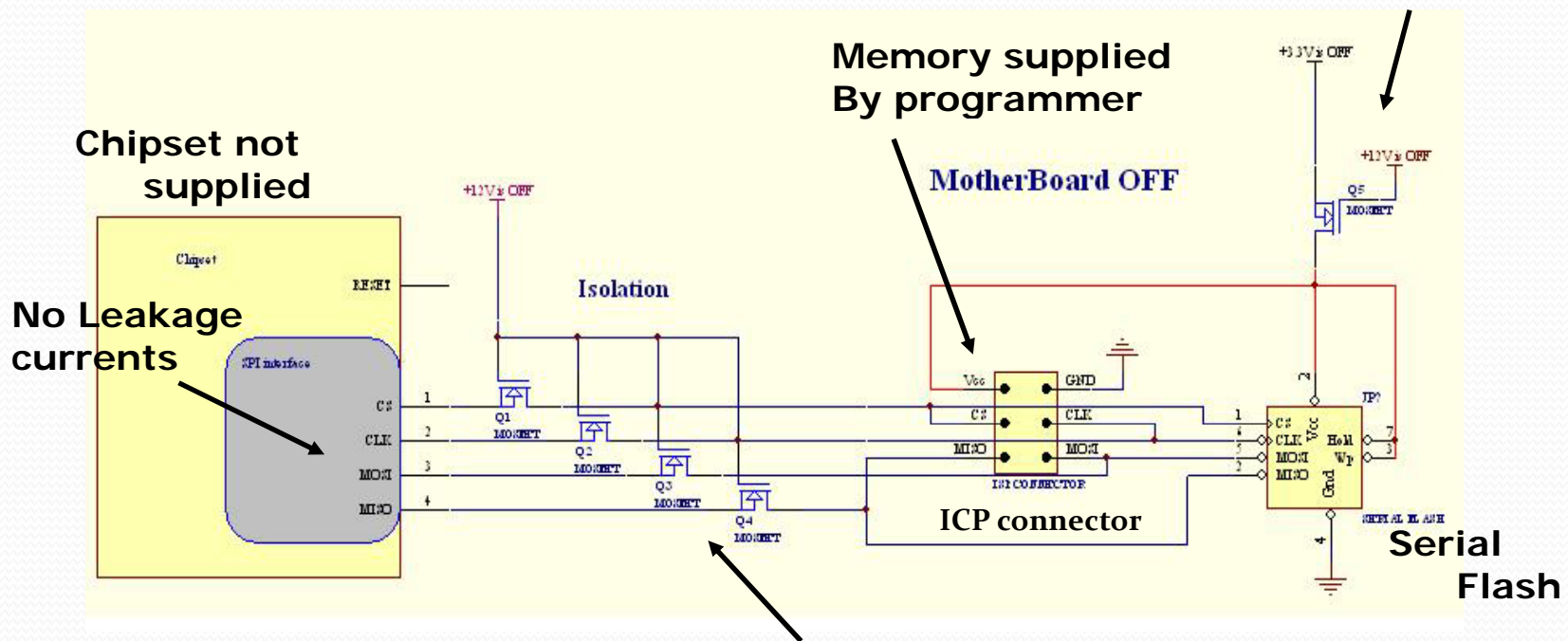

Chipset not supplied

No Leakage currents

Memory supplied By programmer

MotherBoard OFF

Mosfet to isolate the chipset during the ICP update with application OFF:

- Application ON → MOSFET ON
- Application OFF → MOSFET OFF

Conditions:

- Work with all the chipsets

Case 3: Update the Serial Flash with Application ON and SPI Output in High impedance

Chipset reset by programmer IO3 before starting the SF update

Memory supplied By application only

MotherBoard ON only

Chipset supplied

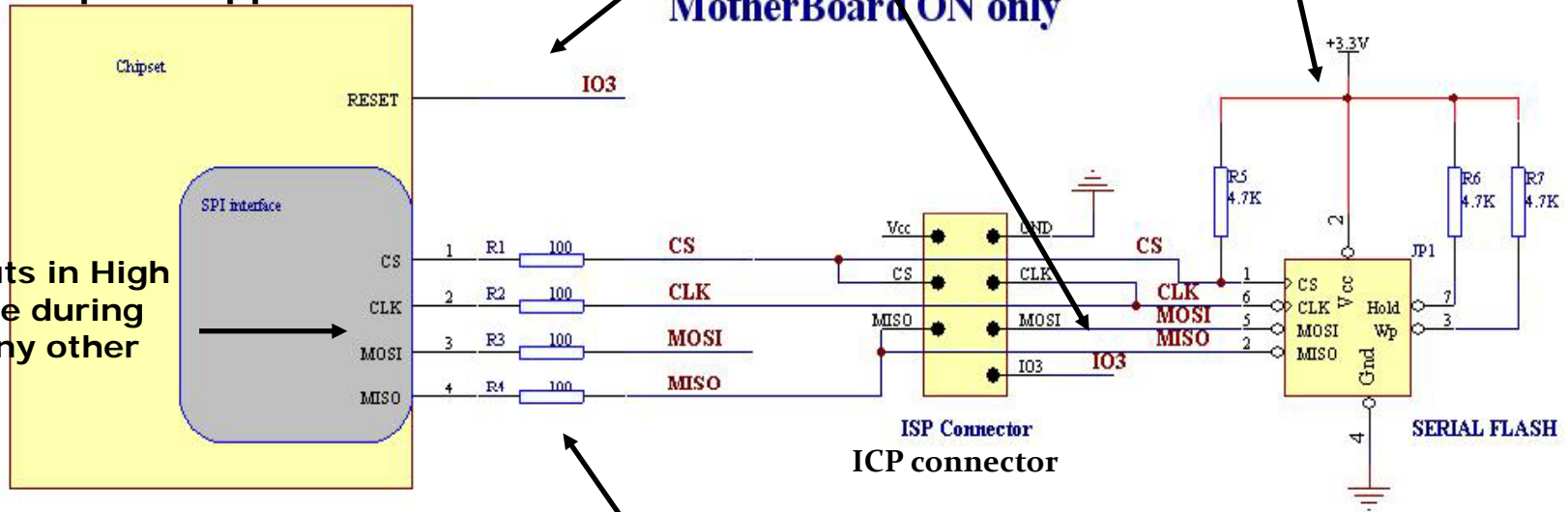

SPI Outputs in High Impedance during reset or any other modes..

Conditions:

Chipset SPI outputs must be in High Impedance during the ICP update (reset or any other modes..)

SPI Serial resistors (33 or 47 Ohm) to:
Filter the SPI signals overshoots and undershoots on edges



Case 4: Update the Serial Flash with Application ON and Mosfet

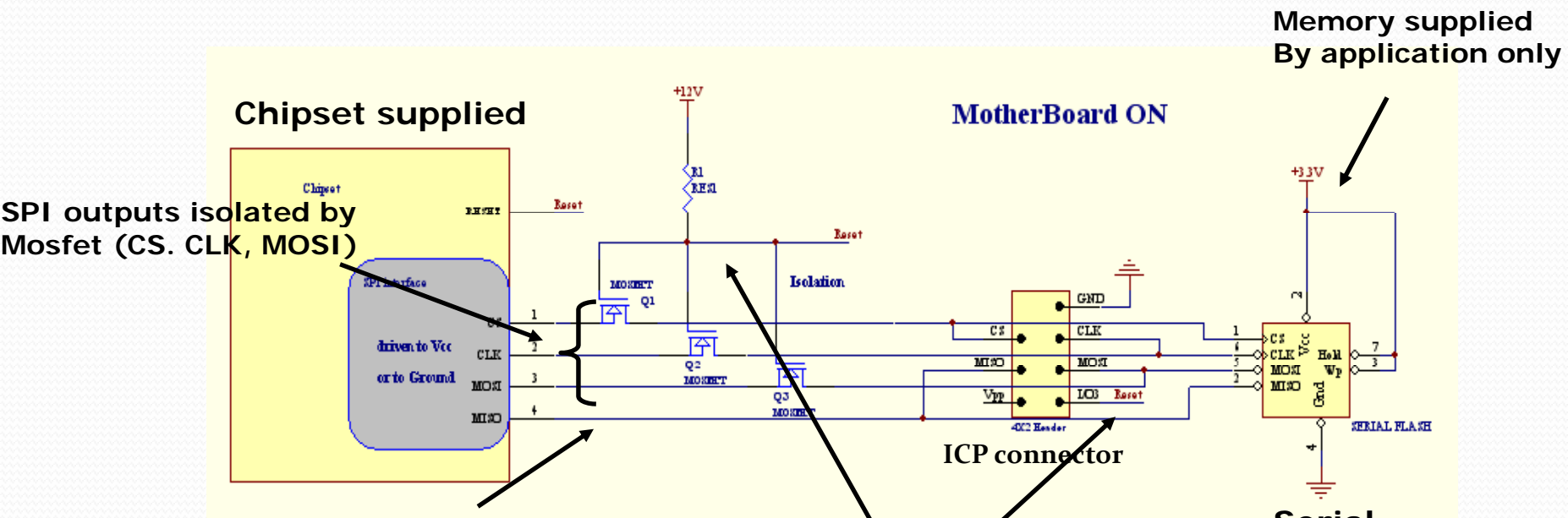

SPI outputs isolated by Mosfet (CS, CLK, MOSI)

SPI Input doesn't need to be isolated (MISO)

SF100 and SF300 IO3 connected to the Mosfet gates. Mosfet are supplied by the application but switched off by the IO3 during the ICP update

- No update → MOSFET ON (chipset connected)
- Update → MOSFET OFF (chipset isolated)

Conditions:

- Work with all the chipsets

How can I validate the ICP method with my chipset and application?

The direct ICP method will require a minimum of validation. Actually, the programmer is taking control of the SPI bus and Memory power supply so it is mandatory to check if there is no possible conflict with the application controller (SPI master) or with the application Hardware.

For this purpose, DediProg has designed “ICP Evaluation tool” to test and validate the different In Circuit Programming methods on your current application board without any hardware change required.

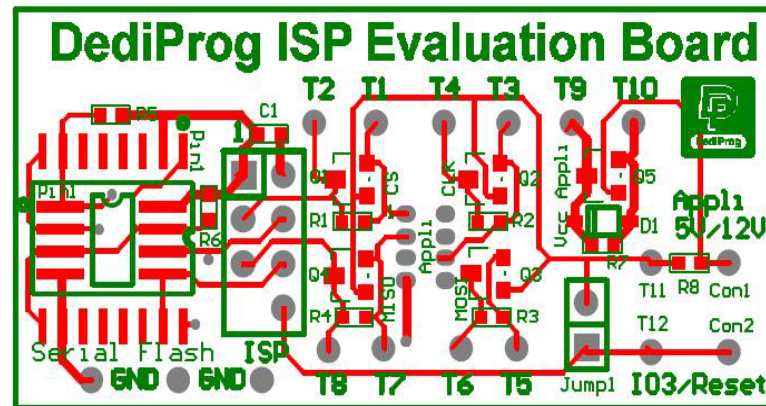

ICP Evaluation Board connection

The ICP evaluation board can be soldered in your current application board in place of your Serial Flash. The ICP evaluation board is designed to support all the different hardware circuits needed to validate the ICP.

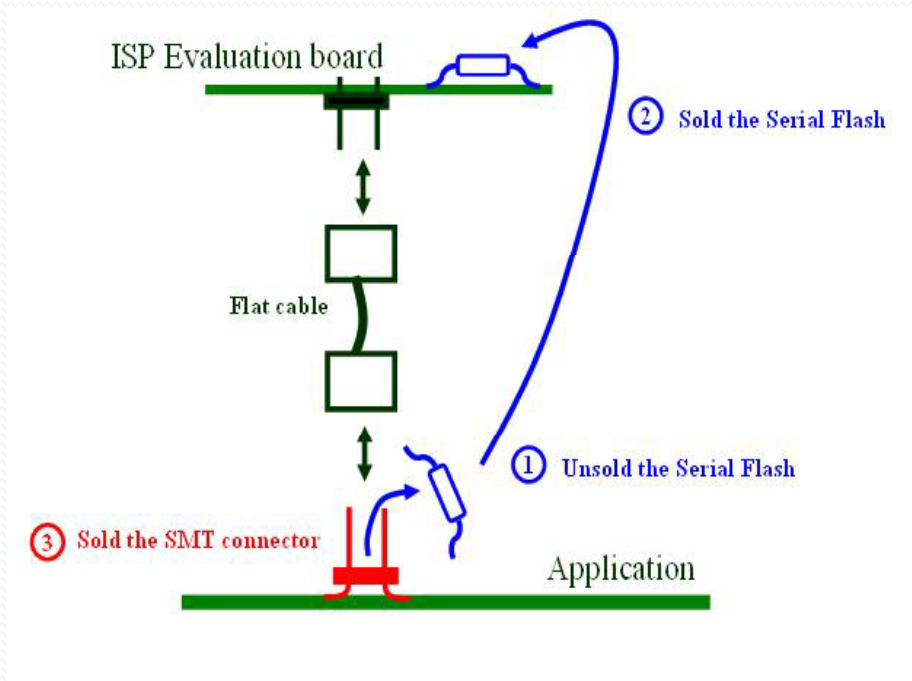

ICP Evaluation Board schematic

User can test all the combinations:
SPI → MOSFET or Serial resistors
Vcc → Mosfet or Diode or shortcut

Connect IO3 to the Mosfet gate or application reset

- T1 = Test Point for CS controller side
- T2 = Test Point for CS Serial Flash/Programmer side
- T3 = Test Point for CLK controller side
- T4 = Test Point for CLK Serial Flash/Programmer side
- T5 = Test Point for MOSI controller side
- T6 = Test Point for MOSI Serial Flash/Programmer side
- T7 = Test Point for MISO controller side
- T8 = Test Point for MISO Serial Flash/Programmer side
- T9 = Test Point for Vcc Serial Flash side
- T10 = Test Point for Vcc Application side
- T11 = Test Point for MOSFET Gates
- T12 = Test Point for IO3 Programmer signal
- Con1 = connect the application 3.3V or +5V or 12V
- Con2 = connect to the application system reset

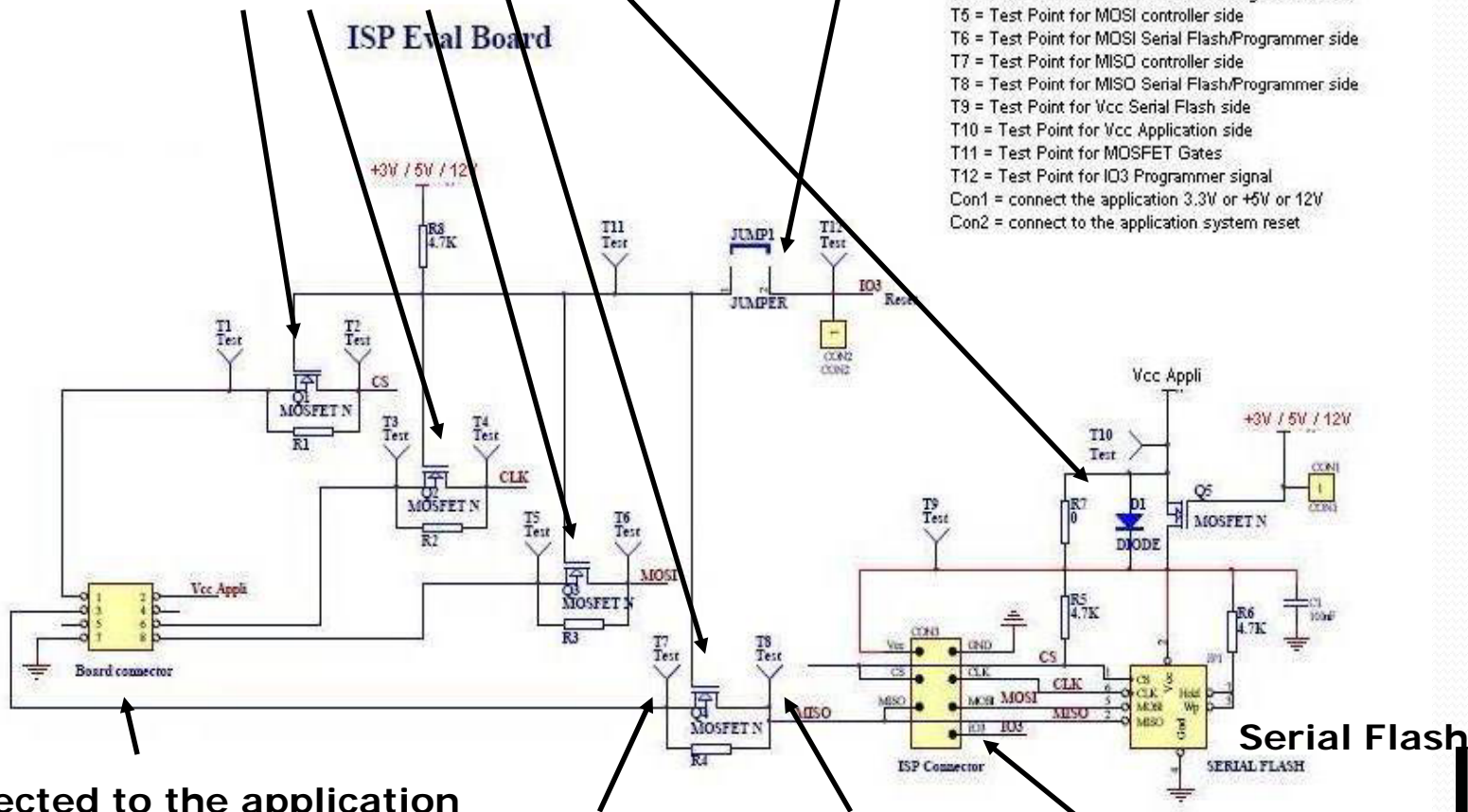

Connected to the application
 (Serial Flash Footprint)

Test points are used to check
 The signals with oscilloscope

Connect SF100
 Or SF300



Programmer extra features

The SF100 and SF300 has been designed to support the update of two different Serial Flash soldered on the application board with two extra pins on the ICP connector. User has just to select the target memory on the DediProg Software: Chip1 or Chip2



The application ICP connector can be saved by using our SO test clip to connect the programmer directly on the serial Flash package: SO8N, SO8W or SO16



More information on the SF100, SF300 programmers and ICP evaluation kit on: www.DediProg.com



's-Hertogenbosch - Den Dungen - The Netherlands

Your PC and Communication Technology Partner

Eltan is a European advanced engineering services company and the “core” competence is PC and Communication technology. Eltan provides specialized high-quality engineering services for hardware, Bios and operating systems as well as complete system solutions.

Eltan is a Master distribution and development partner from Phoenix Technologies. Our engineers have experience and implemented Phoenix products since 1988. Eltan customizes the BIOS code of Phoenix to the customer hardware platform and offers object and source code license agreements fit for industrial and embedded suppliers. Eltan offers these development, engineering and customization services for Phoenix SecureCore Tiano, SecureCore, Embedded BIOS, Phoenix Award Bios, Phoenix GenSW BIOS, UEFI and full legacy compliant. Eltan engineers have implemented hundreds of customer specific BIOS-based features. To name some: Console redirect, ACPI, Security, pre-boot communication, Boot from SD, USB and 1394.

Eltan designs and brings leading edge hardware to production. Eltan is specialized in designing customer specific boards based on x86 technology. Eltan covers the Intel, AMD and VIA Technologies standard and embedded processor lines. This includes Embedded Controller and FPGA combined hardware and software solutions. Some examples of products are: Motherboards (Industrial, embedded, and regular), Information Appliances, PC on a Chip based board solutions, Server blades, Network switches. Eltan's expertise ensures a planned and controlled design cycle enabling successful production startup, approvals & certification and meeting your planned time to market.

Eltan supports you with Operating systems and Driver development for Microsoft Windows CE, XP, 2000, Vista, Windows 7, Server 2008 and Linux. Eltan's experience with File System Filter Drivers, Boot loaders (e.g. for Windows CE), Hardware Device Drivers, Filter Drivers and Operating System Configuration improves your time to market and will reduce the overall project cost

Eltan offers licensing and engineering support for the Phoenix family of products. These products are targeted at board and system manufacturers and reduce support cost and add value to the customer's products. Based on the in house BIOS expertise and the Phoenix Partnership Eltan provides engineering services to create Bios Protected Applications.

Eltan reduces your time to market for industrial, consumer electronics and Information Appliance products. Eltan offers licensing and engineering support for the software as well as hardware and system engineering.



ELTAN B.V. - Het Schild 13 - 5275 EB Den Dungen - P.O. Box 29 - 5275 ZG Den Dungen - The Netherlands
Tel: +31 (0)73-5944660 - Fax: +31 (0)73-5941187 - E-mail: info@eltan.com - WEB: www.eltan.com
Kvk: 1810499 - BTW / VAT no: NL807380507B01 - Bank: 51.32.90.583 ABN-AMRO